

Ministry of Scientific Research and Innovation

A First Look at Tone  
in the Ncane Noun Phrase

Richard L. Boutwell

SIL

B.P. 1299, Yaoundé

Cameroon

2015

This paper concerns the Ncane language spoken in Misaje Subdivision, Donga-Mantung Division, in the North West Region of Cameroon.

ISO 639-3 language code: ncr

## Table of Contents

Abbreviations .....	iii
Tone Diacritics .....	iii
<b>1 Introduction</b>	<b>1</b>
1.1 Language Situation .....	1
1.2 Corpus and Nature of the Research.....	1
1.3 The Nchane Tone System .....	2
<b>2 Tone of Nouns</b>	<b>3</b>
2.1 Tone on the Noun Class Prefix .....	3
2.2 Tone on Noun Roots .....	5
2.3 Phrase Final Lowering of Mid Tones.....	8
2.4 Automatic Downstep of High Tones.....	9
2.5 Prefix Nasals and Lowering of Gender 1a/2a Mid Tones .....	11
2.6 Lowering of Low Tone Roots .....	14
<b>3 Areas for Further Research</b>	<b>16</b>
References .....	17

## Abbreviations

↓	Downstep	C	Consonant
(H)	Floating high tone	C <sup>w</sup>	Labialized consonant
(L)	Floating low tone	H	High tone
(M)	Floating mid tone	L	Low tone
AM	Associative marker	M	Mid tone
c1	Class 1	N	Nasal archiphoneme
c2	Class 2	P0	Immediate/unspecified past
c3	Class 3	SL	Super low tone
	etc.		

## Tone Diacritics

ṽ	Low tone	Ṃ	High-Low falling tone
ṽ̄	Mid tone	Ṃ̄	Mid-Low falling tone
ṽ̂	High tone	Ṃ̂	High-Mid falling tone

# 1 Introduction

## 1.1 Language Situation

Ncane<sup>1</sup> is a language spoken in the Misaje Subdivision, Donga-Mantung Division, North West Region of Cameroon, West Africa. Dieu and Renaud (1983), in the *Atlas Linguistique du Cameroun (ALCAM)*, list the language as: Ncane [873]. The *Ethnologue* (Lewis, Simons, and Fennig 2015) lists the following as language name variations: Ncane, Nchanti, Ntshanti, Cane (ISO 639-3 language code: ncr). Furthermore, Lewis et al. (2015) give the genetic affiliation as: Niger-Congo, Atlantic-Congo, Volta-Congo, Benue-Congo, Wide Bantu, Southern, Beoid.

The language is spoken predominately in five villages: Nkanchi, Nfume, Chunghe, Bem and Kibbo. There are approximately 22,000 speakers of the language, although the exact number is unknown as there are reportedly sizeable clusters of Nchane speakers living outside the area, particularly in the Southwest Region. The Nchane people are positively disposed toward their language, which is spoken by young people as well as old people and is the language of choice in Nchane homes. It is also frequently used in local churches and during community events.

A significant number of Nchane people may be fluent in Noni, the neighboring language group to the south. However, the majority of communication between the two people groups, as witnessed in common market places, is Cameroonian Pidgin English, which a majority of Nchane speakers can speak with at least a minimum of functionality.

## 1.2 Corpus and Nature of the Research

The current paper is an early effort to describe the tone of the noun phrase. Data for the research comes primarily from a wordlist and tone frames. The wordlist was elicited in 2006 in the village of Nfume with assistance from Shey Tamfu Ephraim. The tone frames were collected in 2014-2015 in Bamenda, with the aid of Sjinkwe Thomas.

Certain conventions have been observed in the paper and the reader is encouraged to take note of following items related to the presentation of the data. The segmental data is presented utilizing orthographic forms. The main graphemes of concern are “ch” for [tʃ],

---

<sup>1</sup> “Nchane” is the currently accepted orthographic form of the language name and preferred by the community when used in English writing. Therefore, this form will be used throughout the remainder of the paper.

“sh” for [ʃ], “j” for [dʒ] and “y” for [j]. The reader is directed to the *Nchane Orthography Guide* (Boutwell and Boutwell 2008) for aid in realizing their phonetic forms.

### **1.3 The Nchane Tone System**

The Nchane tone system shows seven distinct tone melodies which are made up of three level tones: L, M and H. Each of these level tones is observed as a simple tone melody. The three tones also combine to make four different contour tone melodies: three falling melodies (HM, HL and ML) and one rising melody (MH).

Several tone phenomena are observed and will be treated below, beginning with phrase final lowering. Automatic downstep of H tones happens when preceded by a non-H tone, resulting in a lowering of the tone register. There are two other manifestations of lowering, both temporary in nature. One involves the lowering of L tone roots and the other the lowering of adjacent tones. Both of these last expressions of tone lowering appear to be related to prefix nasals, which will be discussed in some detail. In summary, there are four different processes which lower certain tones in a variety of environments.

## 2 Tone of Nouns

### 2.1 Tone on the Noun Class Prefix

The class prefix of most noun classes carries a M tone. This is illustrated in example 1 below with classes 7 and 25.

- |    |     |                |                    |
|----|-----|----------------|--------------------|
| 1. | M-H | <b>kī-bó</b>   | arm (c7)           |
|    | M-M | <b>kī-bēŋ</b>  | calabash (c7)      |
|    | M-L | <b>kī-mbì</b>  | small drum (c7)    |
|    | M-H | <b>māŋ-kó</b>  | ladders (c25)      |
|    | M-M | <b>mān-shē</b> | inheritances (c25) |

Classes 2 and 2a also appear to have a M prefix. However, this analysis for class 2a is complicated by the presence of a prefix nasal. The homorganic nasal /N/ before another consonant lowers the M prefix a bit, as seen in the example below where a class 7 M root noun is compared with a class 2a M root noun.

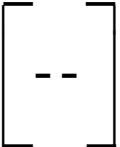
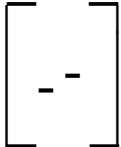
- |    |   |   |
|----|---|---|
| 2. |  |  |
|    | M-M   | M-M   |
|    | <b>ki-beŋ</b>   | <b>ban-fa</b>   |
|    | c7-calabash   | c2a-eagle   |

This slight lowering of mid tone prefixes with a nasal always occurs in phrase initial position and does not affect following tones. Lowering of mid tone prefixes also occurs when the word is preceded by a word that ends in a L tone, but here the prefix is lowered all the way to a L tone. This lowering will be discussed in more detail in section 2.5 below.

Class 1 has no segmental prefix and no tone associated with the prefix position. Class 1a accounts for 80% of class 1/class 1a nouns and has a syllabic nasal prefix with a M tone.

3.	H	<b>chóŋ</b>	thief (c1)
	L	<b>lè</b>	oath (c1)
	M-H	<b>ṅ-gáŋ</b>	scorpion (c1a)
	M-M	<b>ṅ-fā</b>	eagle (c1a)
	M-L	<b>ṅ-kùŋ</b>	box (c1a)

The same prefix nasal lowering effects described above for c2a are observed in the c1a nouns. This class will be discussed in more detail in section 2.5 below.

Classes 19 and 18a have a L tone prefix.

4.	L-H	<b>fi-láŋ</b>	pipe (c19)
	L-M	<b>fi-nchā</b>	ring (c19)
	L-H	<b>mù-nyí</b>	bird (c18a)
	L-M	<b>mù-mbiēŋ</b>	bow (c18a)

Classes 3, 4 and 5 have no segmental prefix nor any tone associated with the prefix position.

5.	H	<b>gwí</b>	net (c3)
	M	<b>kwēŋ</b>	firewood (c3)
	H	<b>kīī</b>	months (c4)
	M	<b>bēŋ</b>	mosquitoes (c4)
	H	<b>lú</b>	marriage (c5)
	M	<b>sōŋō</b>	oil palm (c5)

The singular and plural forms of gender 9/10 nouns are differentiated by tone alone. Class 9 nouns are relatively low and class 10 nouns are relatively high. The behavior of tone in these 9/10 nouns is not well understood at this time. Thus, this paper does not include an in-depth analysis of the nouns of these two classes.



Below is a table summarizing the underlying tone of the noun class prefixes.

Class	Prefix	Class	Prefix
1/1a	/N̄-	2/2a	bā-/bāN-
3	C <sup>w</sup> -	4	C-
5		6	ā-
7	kī-	8	bī-
9	`	10	´
14	bū-	25	māN-
19	fī-	26	mù-
		27	chī-

**Table 1. Noun Class Prefixes**

## 2.2 Tone on Noun Roots

Of the seven melodies attested, each is observed on c7 roots. Therefore, c7 will be used to illustrate tone on noun roots, which are marked with phonemic tone in the examples below. The H melody occurs in 14% of the nouns and is observed in all noun classes.

6. **kī-bó** arm  
**kī-yá** ram  
**kī-ntóŋ** drum  
**kī-yáyá** flying ant  
**kī-mbémé** caterpillar

The M melody is the most prevalent melody, occurring in 18% of nouns. Again, this melody is observed in all noun classes.

7. **kī-bāa** horn  
**kī-tē** tree  
**kī-bēŋ** calabash  
**kī-bēmē** dove  
**kī-ŋkūfē** bone

The L melody is less common, occurring in only 10% of nouns. Furthermore, the distribution is quite narrow, limited to classes 1, 1a, 2, 2a, 7, 8, 19 and 18a. Almost all occurrences are found on monosyllabic roots. The L melody will be discussed in more detail in section 2.6 below.

8. **kī-mbì**            small drum  
**kī-nchà**            marsh  
**kī-ndòŋ**            neck

The HM melody occurs in 11% of nouns. All classes but 14 and 25 are represented.

9. **kī-kó**            forest  
**kī-jéŋ**            fly

The HL melody occurs in 15% of nouns and is observed in all classes except for 4, 14 and 25. Of note is that, while most of the occurrences of the other melodies are 60-80% with monosyllabic roots, 69% of occurrences of the HL melody are with disyllabic roots. It might be that many of the nouns in this group are derived or otherwise complex.

10. **kī-kâ**            charcoal  
**kī-jwí**            boundary  
**kī-ŋgûŋ**            bedbug  
**kī-kólè**            bastard  
**kī-mbéjì**            mudfish

The ML melody is as prevalent as the M melody, occurring in 18% of nouns. It is observed in all classes except for 3, 4 and 6.

11. **kī-kè**            bag  
**kī-bè**            wing  
**kī-tàŋ**            fence  
**kī-ntāsè**            trap  
**kī-ŋgōnè**            cock

The MH melody is the rarest melody, occurring in only 5% of nouns.<sup>2</sup> All occurrences are with prenasalized disyllabic roots. As with the HL group, these nouns might all be derived.

12. **kī-ŋkōgó**      wound  
    **kī-mbōné**      peace

In summary, the most common tone melodies are M and ML, and contour tone melodies are overall more prevalent, with only 42% of nouns having level tone melodies. The L tone melody, while not uncommon, has a narrow distribution and presents syllable type preferences, with monosyllabic roots strongly dominant. Finally, the sole rising tone melody MH is the least common of the tone melodies and also shows definite syllable restrictions, with all member nouns possessing prenasalized disyllabic roots.

---

<sup>2</sup> Nine percent of the nouns in the corpus have yet to be assigned an analysis of underlying tone.

### 2.3 Phrase Final Lowering of Mid Tones

A phrase final M will slightly lower if it is preceded by a H. This lowering is observed even when the M has another (non-lowered) M intervening between it and the H, as illustrated in examples 14 and 15 below.

13.  $\left[ \begin{array}{ccc} - & - & - \\ \text{M} & \text{H} & \text{M} \\ \mathbf{b\epsilon\eta} & \mathbf{b\epsilon} & \mathbf{kw\epsilon\eta} \\ \text{c4.mosquito} & \text{and} & \text{c3.firewood} \\ \text{'mosquitoes and firewood'} \end{array} \right]$

14.  $\left[ \begin{array}{ccc} - - & - & - - \\ \text{M-M} & \text{H} & \text{M-M} \\ \mathbf{ki-b\epsilon\eta} & \mathbf{b\epsilon} & \mathbf{ki-te} \\ \text{c7-wing} & \text{and} & \text{c7-tree} \\ \text{'wing and tree'} \end{array} \right]$

15.  $\left[ \begin{array}{ccccc} - & - & - & - & - - \\ \text{H} & \text{M} & \text{'H} & \text{M} & \text{M-M} \\ \mathbf{gwi} & \mathbf{wu} & \mathbf{lu} & \mathbf{chi} & \mathbf{ki-te} \\ \text{c3.net} & \text{c3AM} & \text{c5.marriage} & \text{c5AM} & \text{c7-tree} \\ \text{'net of marriage of tree'} \end{array} \right]$



In the example below, the M of the c7 prefix causes the H root to downstep. This is followed by the M of the class 7 associative marker causing the H of ‘marriage’ to downstep a second time.

18.  $\left[ \begin{array}{cccccc} - & - & - & - & - & - \\ (H).H & H & M-{}^{\prime}H & M & {}^{\prime}H & \end{array} \right]$   
**shi**    **bε**    **ki-yuŋ**    **ki**    **lu**  
 c10.fowl    and    c7-fool    c7AM    c5.marriage  
 ‘fowls and fool of marriage’

While the above examples have shown downstepping of noun roots, the following examples show downstepping of the H on the conjunction **bε**.

19.  $\left[ \begin{array}{ccc} - & - & - \\ - & & \end{array} \right]$   
 HL     ${}^{\prime}H$     (H).H  
**labe**    **bε**    **shi**  
 c5.web    and    c10.fowl  
 ‘web and fowls’

20.  $\left[ \begin{array}{ccc} - & - & - \\ - & & - \\ - & & \end{array} \right]$   
 M-HL     ${}^{\prime}H$     (H).H  
**ba-bvule**    **bε**    **shi**  
 c2-lion    and    c10.fowl  
 ‘lions and fowls’

More work needs to be done on discerning when the register is reset. Nevertheless, the example below shows that, rather than the register resetting at the phrasal boundary, downstepping continues throughout the clause. With a new clause comes a resetting of the register, following the pattern of neighboring languages.

21.

H L M-'H (L).H M-'H H (L).M M-'H

**chəŋ wu ŋ-gaŋ yu ki-guŋ chəŋ mi ki-guŋ**

c1.thief c1AM c1a.scorpion P0.kill c7-baboon c1.thief P0.swallow c7-baboon

'The thief of the scorpion killed the baboon. The thief swallowed the baboon.'

## 2.5 Prefix Nasals and Lowering of Gender 1a/2a Mid Tones

As stated above, 80% of class 1/1a nouns have a syllabic nasal prefix with a M tone. These nasals are resyllabified in normal speech when the when the word preceding the noun ends with a vowel. In phrase initial position, a slightly lowered M is observed on the nasal when the root tone is M or L, the same kind of lowering mentioned in section 2.1 above involving class 2a nouns.

22.

M-H M-M M-L

**ŋ-gaŋ ŋ-fa ŋ-fəŋ**

scorpion (c1a) eagle (c1a) chief (c1a)

The nasal can also be seen to lower the prefix tone more substantially when preceded by one or more L tones. This is observed in class 2a nouns, where the prefix is underlyingly M, but surfaces at a L level as illustrated in the examples below.

23.  $\left[ \begin{array}{ccc} - & - & - \\ - & & - \end{array} \right]$

M-M      L      M-M

**ḡ-dɔŋ      wu      ban-fa**

c1a.flute   c1AM   c2a-eagle

‘flute of eagles’

24.  $\left[ \begin{array}{ccc} & & - \\ - & - & - \end{array} \right]$

L      L      M-M

**kuŋ      wu      ban-fa**

c1.python   c1AM   c2a-eagle

‘python of eagles’



We now compare the preceding examples with the examples below. Example 25 has a prenasalized root in the second noun position, while example 26 has a non-prenasalized root in the second noun position. About 50% of c7 roots are prenasalized, and it might be expected that these nasals would trigger a similar type of lowering as seen above in classes 1 and 2. But these examples show no such lowering. Therefore, we conclude that this kind of prefix lowering of M tones must be related to the prefix nasal of classes 1a and 2a, rather than a general prenasalization phenomenon.<sup>3</sup>

25. 

[	-	- - -	]
L	L	M-MM	
<b>kuŋ</b>	<b>wu</b>	<b>ki-ŋkufe</b>	
c1.python	c1AM	c7-bone	
‘python of bone’			

26. 

[	-	- -	]
L	L	M-M	
<b>kuŋ</b>	<b>wu</b>	<b>ki-chu</b>	
c1.python	c1AM	c7-iron	
‘python of iron’			

---

<sup>3</sup>At present, lowering triggered by nasals has been seen in classes 1a and 2a, but not with classes 7 and 8. Due to classes 19 and 18a having L prefixes, and the relatively small number of prenasalized roots in the remaining classes, it is difficult to discern if nasal lowering occurs in classes other than 1a and 2a. The fact that a grammatical criterion is part of the trigger for this lowering effect suggests that this lowering is not a purely tonal process but more likely a remnant of earlier stages in the history of Nchane phonology.

## 2.6 Lowering of Low Tone Roots

The L of noun roots is lowered to a super low (SL)<sup>4</sup> under certain circumstances. First, the noun must be preceded by a L. Second, the noun must be followed by a H. In the three examples below, we have phrases with three nouns. The first and second nouns have L roots and are joined by the class 1 associative marker, which also has a L tone. Following the second noun is the conjunction **bε**, which has a H tone. The result is a lowering of the second noun root.<sup>5</sup>

27. 

-	-	-	-	-
-	-	-	-	-
L	L	M-SL	<sup>h</sup> H	M-L
<b>le</b>	<b>wu</b>	<b>ba-kuŋ</b>	<b>bε</b>	<b>ki-mbi</b>
c1.oath	c1AM	c2-python	and	c7-small drum
‘oath of pythons and small drum’				

28. 

-	-	-	-	-
-	-	-	-	-
L	L	SL	H	M- <sup>h</sup> H
<b>le</b>	<b>wu</b>	<b>kuŋ</b>	<b>bε</b>	<b>ki-bɔ</b>
c1.oath	c1AM	c1.python	and	c7-arm
‘oath of python and arm’				

<sup>4</sup> This tone is referred to as SL rather than a downstepped L because the lowering effect is only for one syllable, as illustrated in example 27, where the final L is higher than the SL in the middle of the phrase.

<sup>5</sup> Note that the conjunction in example 27 is downstepped, while there is no downstepping in examples 28 or 29. The primary difference between these examples is the tone associated with the prefix of the second noun: c2 has a M prefix and c1 has no prefix. While c1a in example 29 also has a M prefix, the M becomes disassociated upon resyllabification of the nasal prefix resulting in a (M). I suggest, therefore, that a M provides the necessary conditions for downstepping, but a (M) does not. In section 2.4 we stated that downstepping occurs in HLH and HMH sequences. Here we see a different sequence involving downstepping: MSLH. While this sequence is different from those already identified for downstepping, the reader should consider the relatively great height difference between M and SL, which is comparable to that between H and L.



### 3 Areas for Further Research

As this work has been but a first attempt, there are a number of questions remaining regarding tone in the Nchane noun phrase. While this current paper has attempted to provide a beginning analysis of some of the more basic tonal phenomena, the reader should recognize that this analysis is tentative and the author hopes to continue his efforts to confirm and refine the analysis. Below are several areas in need of further attention.

Due to time constraints, little attention was given to downstep and register reset. Section 9 showed that the register resets at clause or sentence boundaries as observed where two sentences end and begin. While this is normal for many languages in the area, it would be good to also look at other occurrences of clause boundaries, for example subordinate clauses, in addition to other structures involving breath pauses, where register reset may also occur. Also missing from this current work is an examination of the various tone phenomena as realized on nouns with disyllabic roots. A cursory observation suggests that, in some cases at least, disyllabic roots seem to behave differently than monosyllabic roots.

Finally, and perhaps most importantly, very little work has been done to describe tone in classes 9 and 10, since early observations suggest that tone output from these classes is fairly complicated. A good analysis of these classes would benefit from a more thorough understanding of the phenomena already addressed in this current work and then how they might differ in classes 9 and 10. This ongoing research will be important to help provide a better understanding of how tone works in this under-documented and interesting Bebid language.

## References

- Boutwell, Katrina L., and Richard L. Boutwell. 2008. *Nchane Orthography Guide*. Yaoundé, Cameroon: SIL. Online at <http://www.silcam.org/download.php?sstid=030401&folder=documents&file=NchaneOrthographyGuide4-jb.pdf>.
- Dieu, Michel, and Patrick Renaud. 1983. *Situation Linguistique En Afrique Centrale--Inventaire Préliminaire: Le Cameroun. Atlas Linguistique de l'Afrique Centrale (ALAC), Atlas Linguistique Du Cameroun (ALCAM)*. Paris: ACCT; Yaoundé: DRGST/CERDOTOLA.
- Lewis, M. Paul, Gary F. Simons, and Charles D. Fennig, eds. 2015. *Ethnologue: Languages of the World*. Eighteenth edition. Dallas, Texas: SIL International.